



H-IP-ASI-B-V3 User Manual



THOR FIBER AND BROADCAST



<https://thorbroadcast.com>

800-521-8467

sales@thorfiber.com

About This Manual

Intended Audience

This user manual has been written to help people who have to use, to integrate and to install the product. Some chapters require some prerequisite knowledge in electronics and especially in broadcast technologies and standards.

Disclaimer

No part of this document may be reproduced in any form without the written permission of the copyright owner.

The contents of this document are subject to revision without notice due to continued progress in methodology, design and manufacturing. THOR shall have no liability for any error or damage of any kind resulting from the use of this document.

Copy Warning

This document includes some confidential information. Its usage is limited to the owners of the product that it is relevant to. It cannot be copied, modified, or translated in another language without prior written authorization from THOR.



DIRECTORY

Chapter 1 Product Outline	4
1.1 Outline.....	4
1.2 Key Features	4
1.3 Principle Chart.....	6
1.4 Technical Specifications.....	7
1.5 Appearance and Description	6
Chapter 2 Installation Guide	8
2.1 Acquisition Check	8
2.2 Installation Preparation.....	8
2.3 Wire's Connection	10
2.4 Signal Cable Connection	10
Chapter 3 Front Panel Operation	13
3.1 General Setting.....	14
Chapter 4 Web-based NMS Management	16
4.1 Login	16
4.2 Operation	16
Chapter 5 Troubleshooting	28



Chapter 1 Product Outline

1.1 Outline

1.2 The H-IP-ASI-B-V3 is Thor's new product that can receive signals via ASI or IP and convert between these formats—ASI to IP or IP to ASI. In addition, it can decode the signal to video/audio interfaces such as HDMI, CVBS, 3G-SDI, as well as output via ASI or IP.



ASI to IP Application Example:

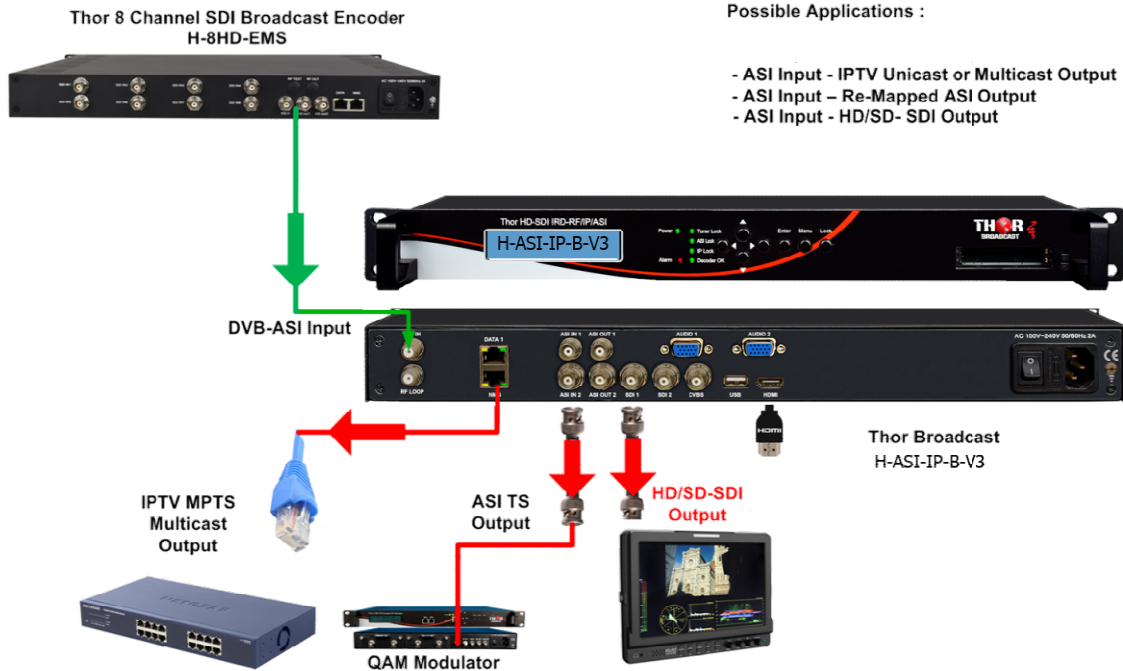

IP to ASI Application Example:



1.3 Key Features

- Demodulator + descrambler +re-mux+decoder in one unit
- 1 or 2 ATSC-T Tuner inputs for option
- 2 ASI & 16 IP UDP/RTP inputs for re-mux
- 1ch HDMI/CVBS/3G-SDI video out (SDI1 and SDI2 mirrored out)
- Support 1ch or 2ch Audios out for option
- Support HD/SD MPEG2, MPEG4 AVC/H.264, HEVC/H.265 and AVS/AVS+decoding
- Support MPEG 1 Layer II, LC-AAC, HE-AAC, HE-AAC V2, Dolby Digital/Dolby Digital Plus decoding and AC3 passthrough
- IP (1 *MPTS &16* SPTS) output over UDP and RTP/RTSP; 2 ASI mirrored out as a copy of the IP MTPS
- Each CAM can decrypt multiple programs from Tuner/ASI/IP
- BISS descrambling (Up to 120Mbps)
- Support CC (EIA608, EIA708) & Teletext (Applicable for SDI port)
- Support maximum 128 PID mapping per input
- LCD/Keyboard and web-based NMS management
- Updates via web

1.4 Principle Chart

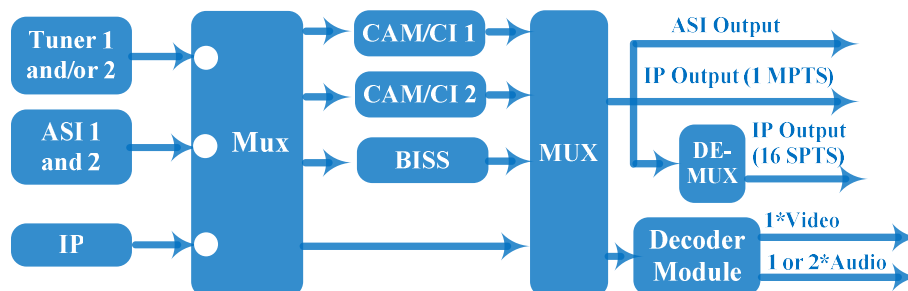

1.5 Technical Specifications

Input	1 or 2 * ATSC-T Tuner for option, F type 2*ASI inputs for re-mux, BNC interface 16*IP inputs for re-mux (UDP/RTP), RJ45			
Tuner Section	ATSC-T	Input Frequency	54~858MHz	
		Bandwidth	6M	
		Constellation	8VSB	
Descrambling	CAM/CI Quantity	2		
	BISS Mode	Mode 1, Mode E (up to 120Mbps)		
Output	IP (1*MPTS &16*SPTS) out over UDP, RTP/RTSP. 1000Base-T Ethernet interface (unicast / multicast)			
	2×ASI mirrored out, BNC interface			
	Decode Output	Video	Interface: 1* CVBS/HDMI/3G-SDI(SDI1 and SDI2 mirrored out)	
			Decode:MPEG-2, MPEG4 AVC/H.264, HEVC/H.265 and AVS/AVS+	
			Resolution:1920×1080_60p, 1920×1080_60i, 1920×1080_50p; 1920×1080_50i; 1280×720_60P, 1280×720_50P; 480i, 576i	
			Chroma: 4:2:0	
	Decode Output	Audio	Interface: HDMI, SDI, DB15 to (XRL, RCA, AES, S/PDIF)	
Number of channels: 1 or 2 for option (as per order)				
Decode: MPEG 1 Layer II, LC-AAC, HE-AAC, HE-AAC V2, Dolby Digital/ Dolby Digital Plus				
Audio Output Mode: Left, Right, Stereo audio				
System	Local interface	LCD + control buttons		
	Remote management	Web-server Management		
	Language	English		
	Upgrade	USB, web management		
Miscellaneous	Dimension	482*300*44.5mm(W×L×H)		
	Approx weight	3.5kg		
	Environment	0~45℃(work); -20~80℃ (Storage)		
	Power requirements	100~240VAC, 50/60Hz		
	Power consumption	20W		

Order Guide

Please specify both **Tuner Input** and **Audio out channel** options when you place order:



Tuner Input	Option 1	1*ATSC-T tuner
	Option 2	2*ATSC-T tuner
Audio Out Channel	Option 1	1*Audio out
	Option 2	2*Audio out

1.5 Appearance and Description

Front Panel Illustration:

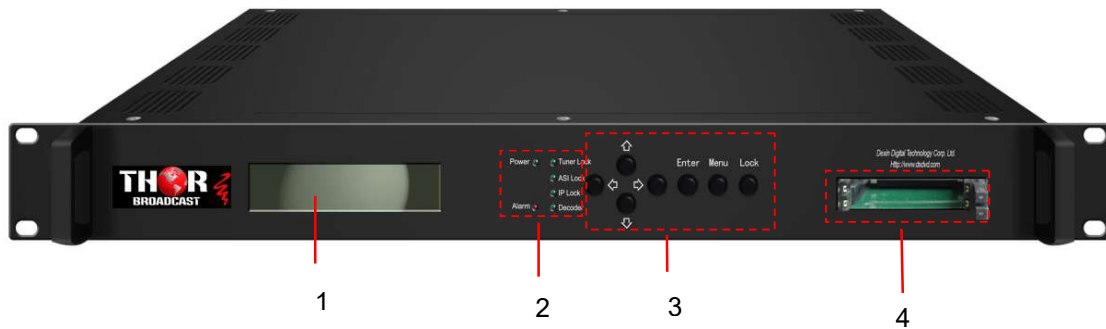

1	monitor LCD display for device control and configuration
2	Indicators Area (to indicate locking status of tuner, ASI and IP input; Decoder: to indicate the decoding status)
3	Up/Down/Left/Right Buttons Enter Key/ Menu Key/ Lock Key
4	CAMs /Smart card slots A & B (A is the lower one)

Rear Panel Illustration

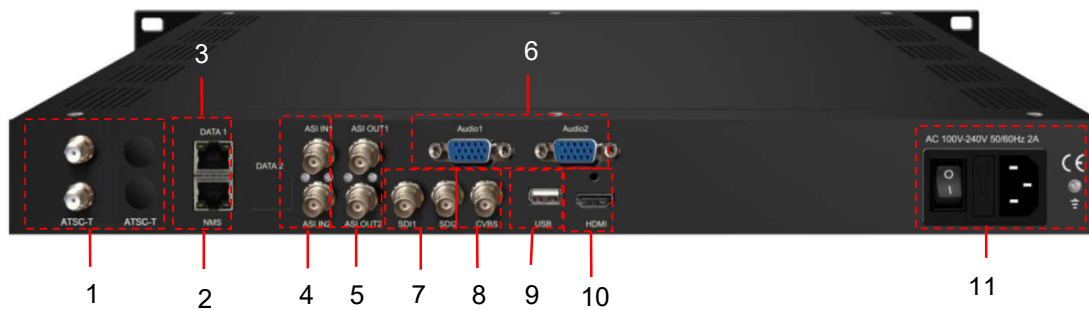

1	ATSC-T tuner input and loop-out (H-IP-ASI-B-V3-2 has two tuners)
2	NMS port for management
3	Data port for IP in and out
4	ASI input Ports for re-mux
5	ASI mirrored output ports
6	Analog audio output interfaces
7	SDI video/audio output interfaces, SDI2 out as mirror of SDI1
8	Composite video output interface (CVBS)
9	USB upgrade port
10	HDMI video/audio output interface
11	Power switch/Fuse/Socket/ Grounding Wire

Chapter 2 Installation Guide

2.1 Acquisition Check

When user opens the package of the device, it is necessary to check items according to packing list. Normally it should include the following items:

- H-IP-ASI-B-V3
- HDMI Cable
- CVBS Cable
- SDI Cable
- Audio adapt cables
- Power Cord
- Ground lead

If any item is missing or mismatching with the list above, please contact our company.

2.2 Installation Preparation

When users install device, please follow the below steps. The details of installation will be described at the rest part of this chapter. Users can also refer rear panel chart during the installation.

The main content of this chapter including:

- Checking the possible device missing or damage during the transportation
- Preparing relevant environment for installation
- Connecting signal cables
- Connecting communication port with PC

2.2.1 Device's Installation Flow Chart Illustrated as following :

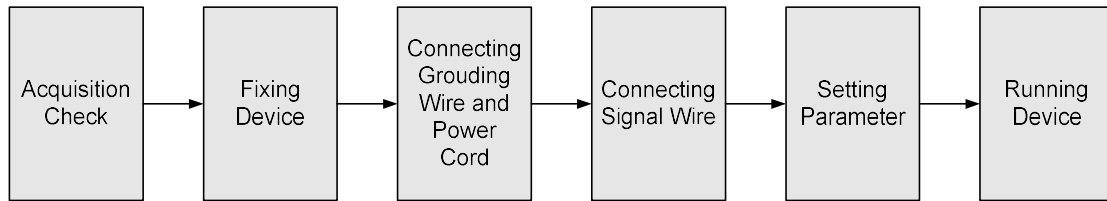

2.2.2 Environment Requirement

Item	Requirement
Machine Hall Space	When user installs machine frame array in one machine hall, the distance between 2 rows of machine frames should be 1.2~1.5m and the distance against wall should be no less than 0.8m.
Machine Hall Floor	Electric Isolation, Dust Free Volume resistivity of ground anti-static material: $1 \times 10^7 \sim 1 \times 10^{10} \Omega$, Grounding current limiting resistance: 1M (Floor bearing should be greater than 450Kg/m ²)
Environment Temperature	5~40°C(sustainable), 0~45°C(short time) , installing air-conditioning is recommended
Relative Humidity	20%~80% sustainable 10%~90% short time
Pressure	86~105KPa
Door & Window	Installing rubber strip for sealing door-gaps and dual level glasses for window
Wall	It can be covered with wallpaper, or brightness less paint.
Fire Protection	Fire alarm system and extinguisher
Power	Requiring device power, air-conditioning power and lighting power are independent to each other. Device power requires AC power 100-240V 50-60Hz. Please carefully check before running.

2.2.3 Grounding Requirement

- All function modules' good grounding is the basis of reliability and stability of devices. Also, they are the most important guarantee of lightning arresting and interference rejection. Therefore, the system must follow this rule.
- Coaxial cables outer conductor and isolation layer should keep proper electric conducting with the metal housing of device.
- Grounding conductor must adopt copper conductor in order to reduce high frequency impedance, and the grounding wire must be as thick and short as possible.
- Users should make sure the 2 ends of grounding wire well electric conducted and be antirust.
- It is prohibited to use any other device as part of grounding electric circuit
- The area of the conduction between grounding wire and device's frame should be no less than 25mm^2 .

2.2.4 Frame Grounding

All the machine frames should be connected with protective copper strip. The grounding wire should be as short as possible and avoid circling. The area of the conduction between grounding wire and grounding strip should be no less than 25mm^2 .

2.2.5 Device Grounding

Connecting the device's grounding rod to frame's grounding pole with copper wire.

2.3 Wire's Connection

- Connecting Power Cord
User can insert one end into power supply socket, while insert the other end to AC power.
- Connecting Grounding Wire
When the device solely connects to protective ground, it should adopt independent way, say, share the same ground with other devices. When the device adopts united way, the grounding resistance should be smaller than 1Ω .

⚠ Caution:

Before connecting power cord to H-IP-ASI-B-V3, user should set the power switch to “OFF”.

2.4 Signal Cable Connection

The signal connections include the connection of input signal cable and the connection of output signal cable. The details are as follows:

2.4.1 H-IP-ASI-B-V3 Cables Illustration:

- **IP Input/output Cable Illustration:**



- **Tuner Cable Illustration:**



- **ASI Input/output Cable Illustration:**



- **Video & Audio output Cable Illustration:**



HDMI Cable

SDI Cable

- **Audio adapt cables Illustration:**



Chapter 3 Front Panel Operation

The front panel of H-IP-ASI-B-V3 is the user-operating interface and the equipment can be conveniently operated and managed according to the procedures displayed on the LCD:

(*Some operations are available for Web GUI only.)

Keyboard Function Description:

MENU: Cancel current entered value, resume previous setting; Return to previous menu.

ENTER: Activate the parameters which need modifications, or confirm the change after modification.

LEFT/RIGHT: Choose and set the parameters.

UP/DOWN: Modify activated parameter or paging up/down when parameter is inactivated.

LOCK: Lock the screen/cancel the lock state. After pressing the lock key, the LCD will display the current configuring state.

3.1 Menu Tree in LCD

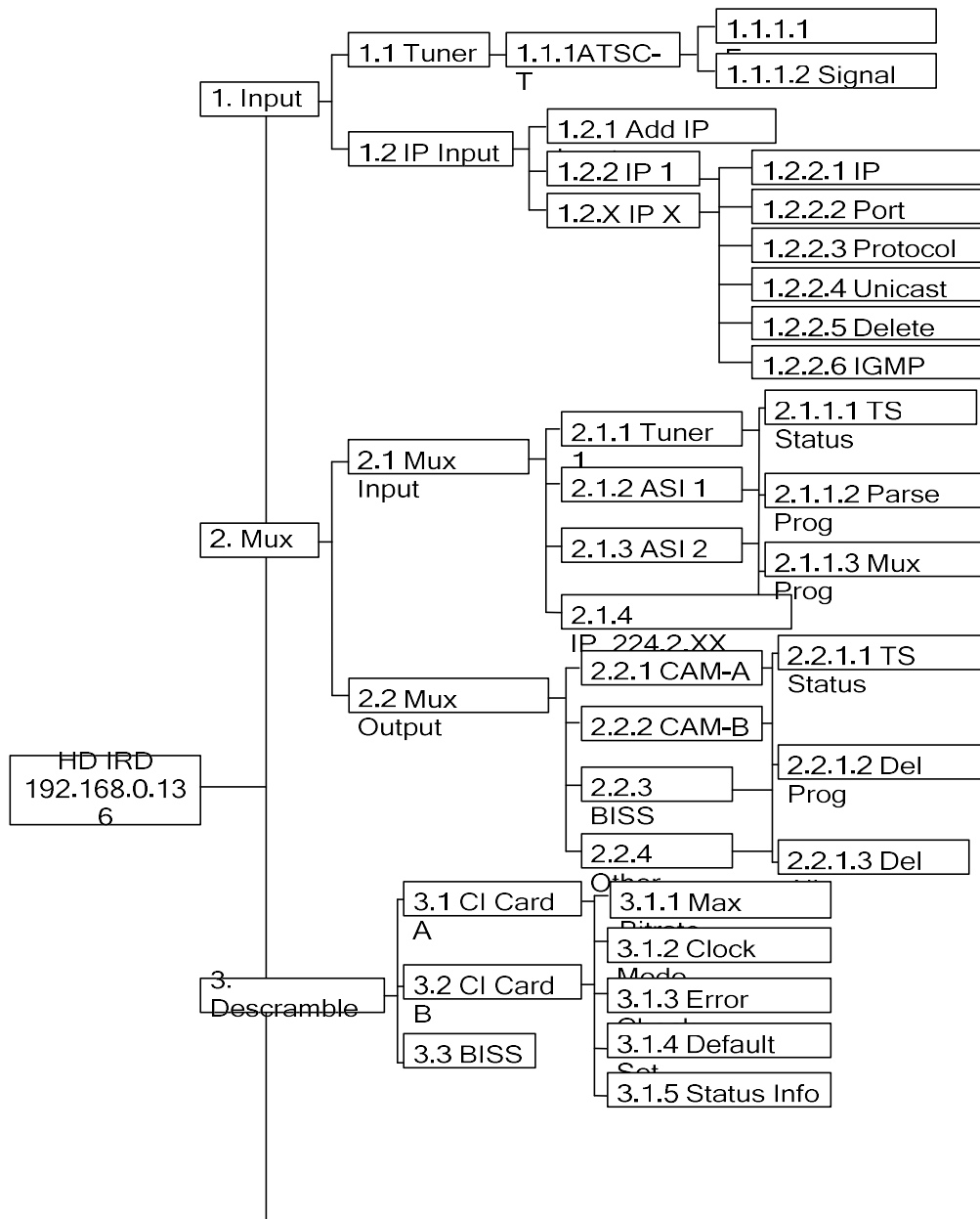

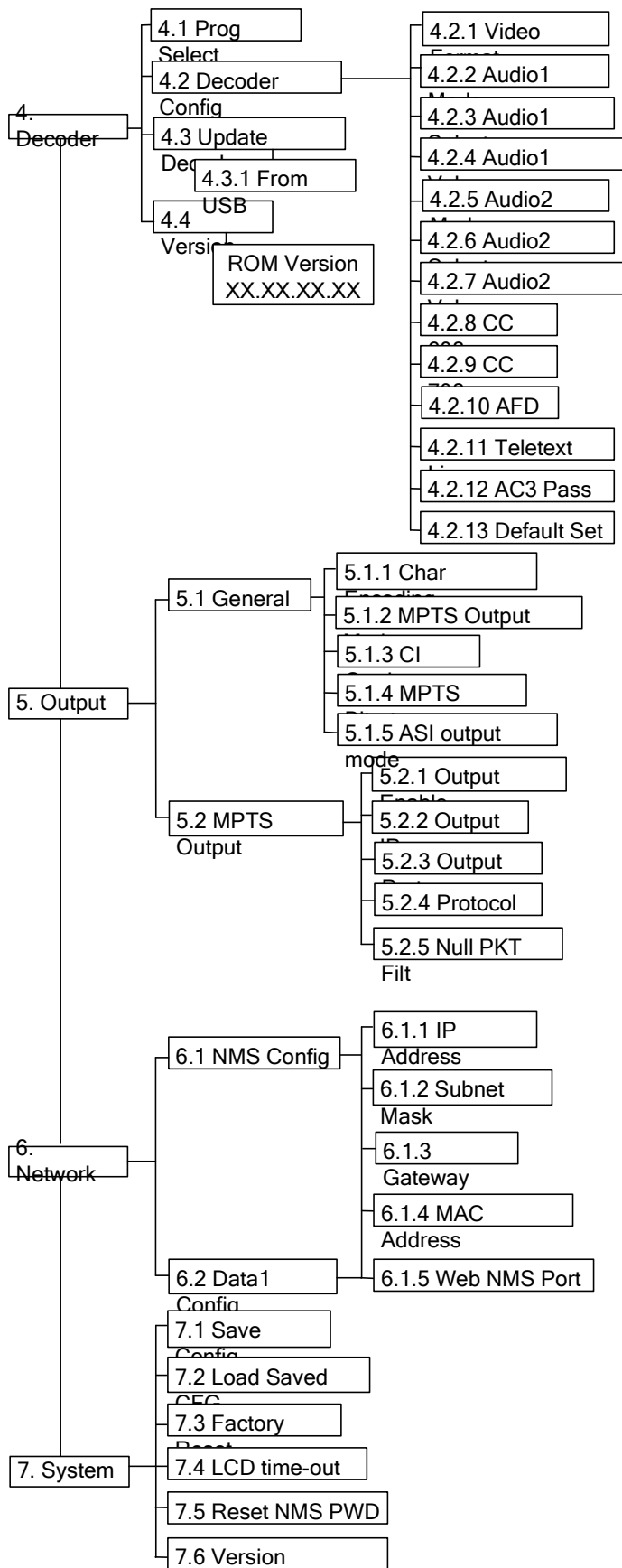

Chapter 4 Web-based NMS Management

Users can use not only the front buttons for a setting, but also the Web GUI for a setting in a computer by connecting the device to web NMS Port. Users should ensure that the computer's IP address is different from this device IP address; otherwise, it would cause IP conflict.

4.1 Login

The default IP address of this device is 192.168.0.136. (We can modify the IP through the front panel.)

Connect the PC (Personal Computer) and the device with net cable, and use ping command to confirm they are on the same network segment.

I.G. the PC IP address is 192.168.99.252, we then change the device IP to 192.168.99.xxx (xxx can be 1 to 254 except 252 to avoid IP conflict).

Use web browser to connect the device with PC by inputting the device's IP address in the browser's address bar and press Enter.

It will display the Login interface as Figure-1. Input the Username and Password (Both the default Username and Password are "admin".) and click "LOGIN" to start the device setting.

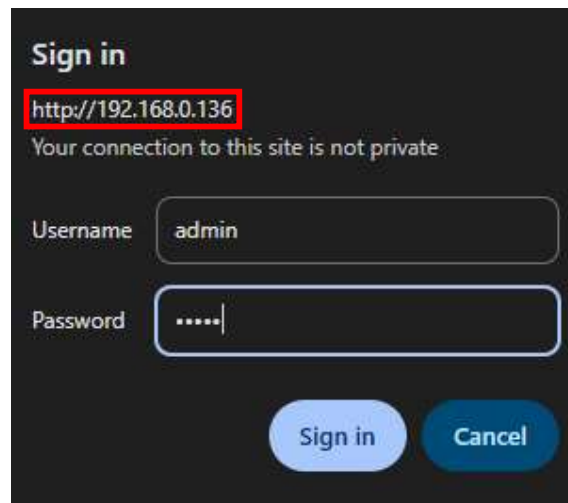

Sign in

http://192.168.0.136

Your connection to this site is not private

Username admin

Password

Sign in Cancel

Figure-1

4.2 Operation

Summary:

After login, it displays the WELCOME interface as Figure-2 where users can have an overview of the device’s system information and uptime.

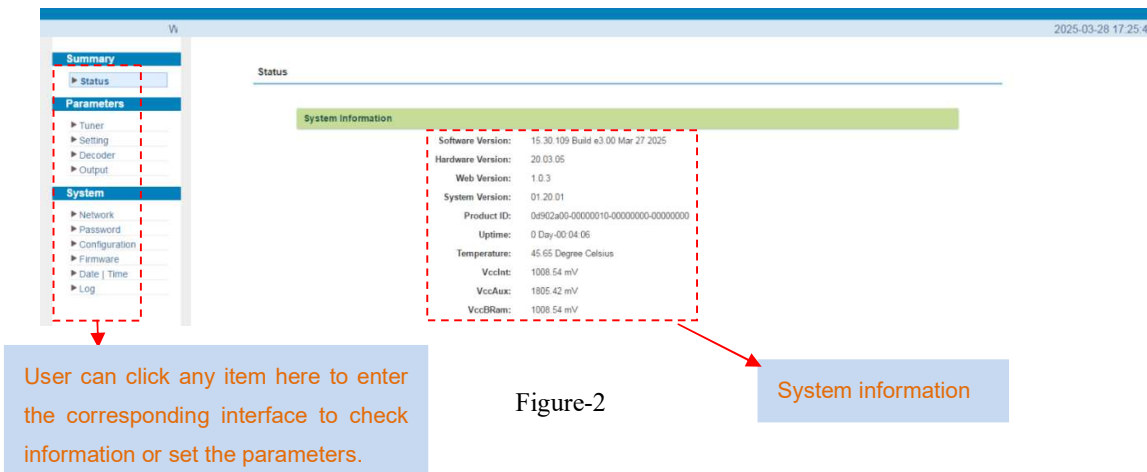

Figure-2

Parameters → Tuner:

Clicking “Tuner”, it displays the TS Lock status, Signal Status and Frequency parameters information of the Tuner inputs. Click “Edit” button to get a pop-up window where users can set the wanted frequency parameters to lock the corresponding signal.

ATSC-T:

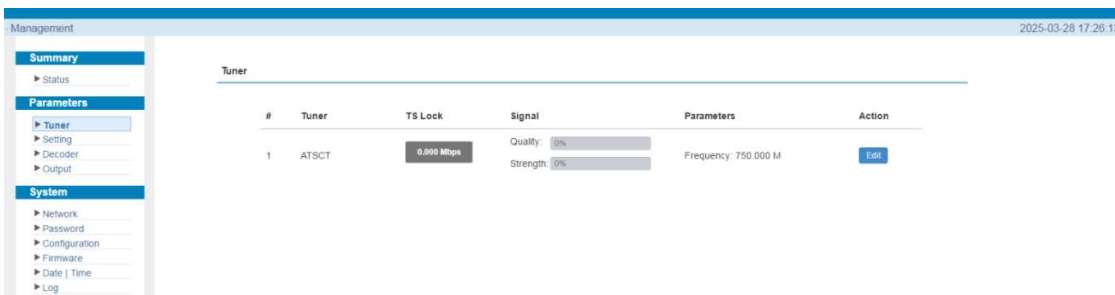

Figure-3

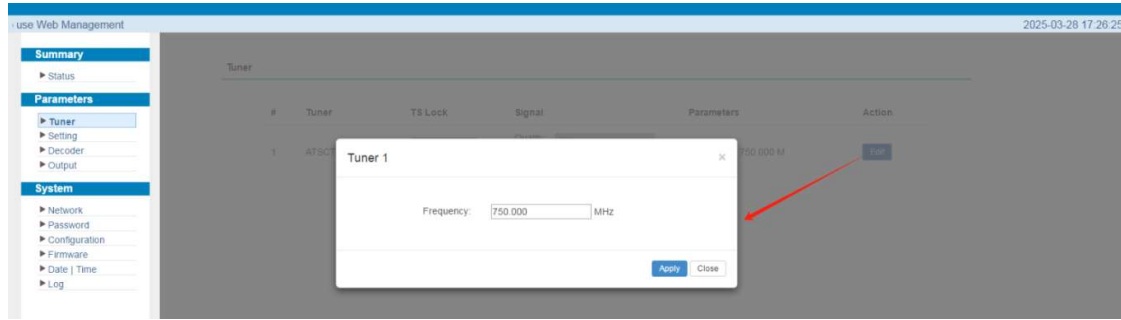

Figure-4

Parameters →Setting:

Click “Setting” for Multiplexing, CI descrambling and BISS descrambling operation etc.

Mux:

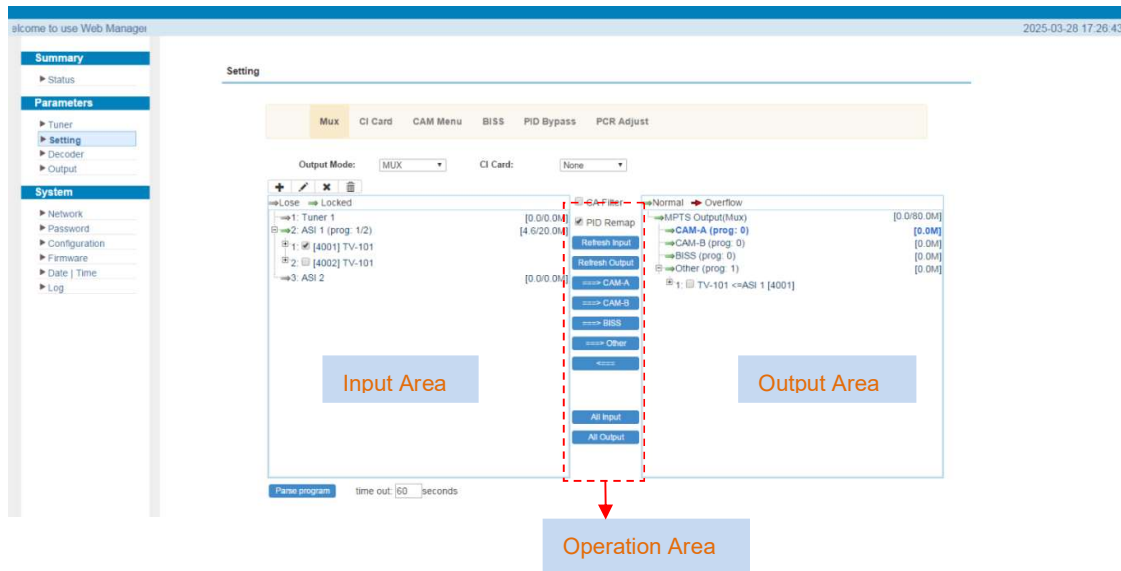

Figure-5

Configure ‘Input Area’ and ‘Output Area’ with buttons in ‘Operation Area’. Instructions are as below:

CA Filter : To enable/disable the CA filter

PID Remap: To enable/disable the PID remapping

Refresh Input To refresh the input program information

Refresh Output To refresh the output program information

==> CAM-A Select the wanted input program(s) firstly and click this button to transfer the selected program(s) to the CAM-A for CI-descrambling setting.



⇒⇒ CAM-B Select the wanted input program(s) firstly and click this button to transfer the selected program(s) to the CAM-B for CI-descrambling setting.

⇒⇒ BISS Select the wanted input program(s) firstly and click this button to transfer the selected program(s) to BISS channel for BISS descrambling setting.

⇒⇒ Other Select the wanted input program(s) firstly and click this button to transfer the selected program(s) to output.

←←← Cancel the multiplexed programs from the output area after your program selection.

All Input To select all the input programs

All Output To select all the output programs

Parse program To parse programs time out: 60 seconds time limitation of parsing input programs

*All the programs in CAM-A, CAM-B, BISS and Other will be in MPTS out.

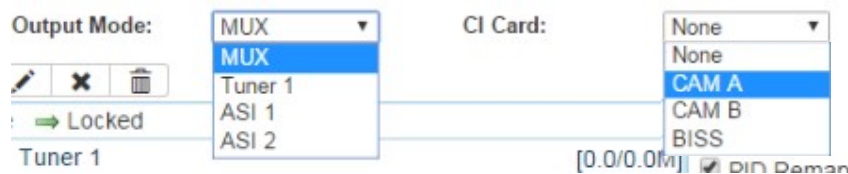

*When Output Mode is MUX, there is no need to specify CI Card, and please keep it as None, because users have chosen the CAM A or B or else during multiplexing operation; When Output Mode is Tuner 1/ASI 1/ASI 2, it is passthrough mode, and users need to specify CAM A or B or else to descramble programs when the related input signals are encrypted.

In Setting-Mux Web page, click “+” button to add the input IP streams.

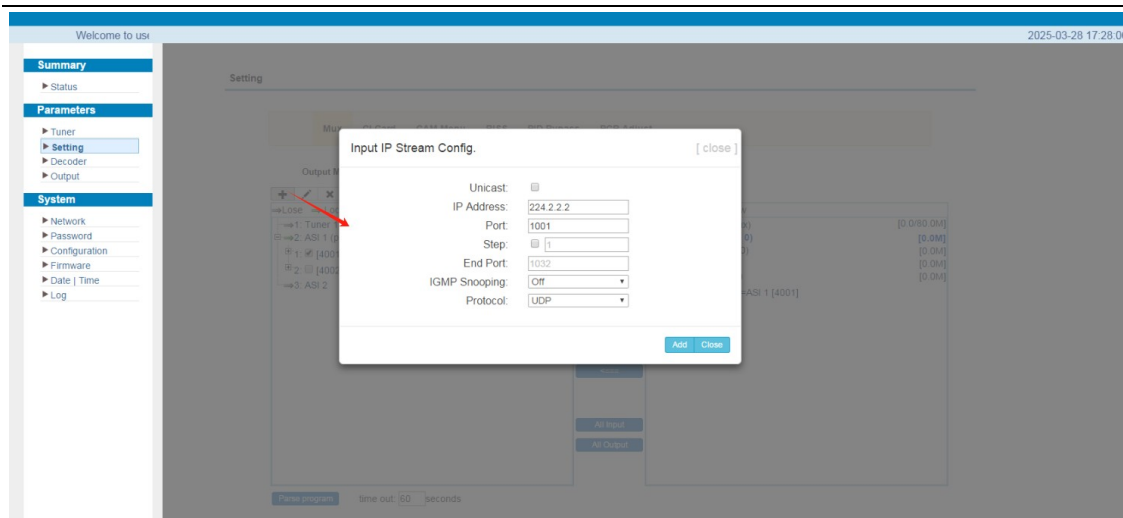

Figure-6

➤ **Program Modification:**

The multiplexed program information can be modified by clicking the program in the

‘output’ area. For example, when clicking **1: TV-101 <=ASI 1 [1]** it triggers a dialog box (Figure 7) where users can input new information

Figure-7

Program Information
[close]

Program From Input: ASI 1 [1]

Service Name:

Short Name:

Major Channel Number:

Minor Channel Number:

Source Id:

Program Number:

Logic Channel Number:

Service Type:

Service Provider:

PMT Descriptor Tag:

PMT Descriptor Data: (Hex)

PMT PID:

PCR PID:

MPEG-4 Video PID:

MPEG-1 Audio PID:

*Type new data and click ‘Save’ button at last to confirm the modification.



*When users add the BISS keys in the BISS web page, please select the corresponding BISS key in the pop-up window to descramble the corresponding programs in BISS channel.

CI Card:

H-IP-ASI-B-V3 supports 2 CI cards (Card A & Card B) to descramble programs from either encrypted Tuners, ASI or IP. Users can click and enter 'CI Card' to configure the 2 cards respectively. (Figure-8)

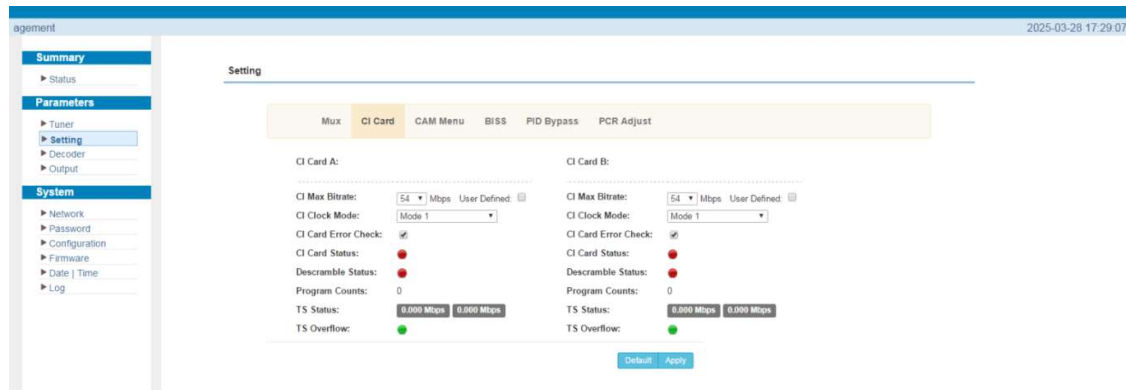
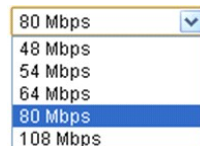

Figure-8

➤ CI Max Bit rate

CI Max Bitrate options range from 48-108Mbps. Select a value in the pull-down list as principle: Actual Input Bitrate ≤ Max Bitrate ≤ CI Max decrypting capacity.

NOTE!



CI Max Bitrate can be defined according to the actual CAM conditions of the users after

checking this box: User Defined.

➤ CI Clock Mode

Usually, Mode 1 is working well in most of the CI-descrambling cases. If you want to change it to Mode 2, please contact our technician for setting guide.

➤ CI Card Error Check

Users can decide whether to enable the card error check function by checking the box.

CI Card Error Check:

After configuring CI card parameters, click button to apply the input data to start



descrambling the selected program(s). The program quantity to be descrambled will depend on the CAM/CI performance you apply to.

CAM Menu:

It shows some communication information during programs descrambling progress in CAM A and B as below.

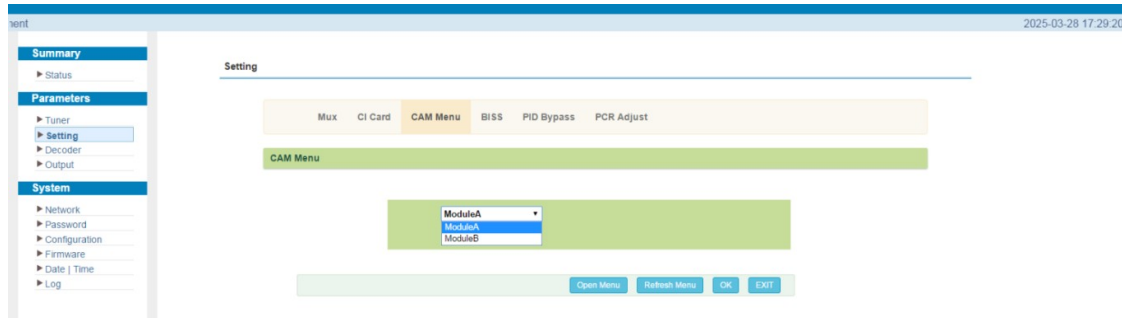

BISS:

Clicking “BISS”, it displays the interface where users can add the BISS keys and descramble the selected programs in the MUX Web page. (Figure-9)

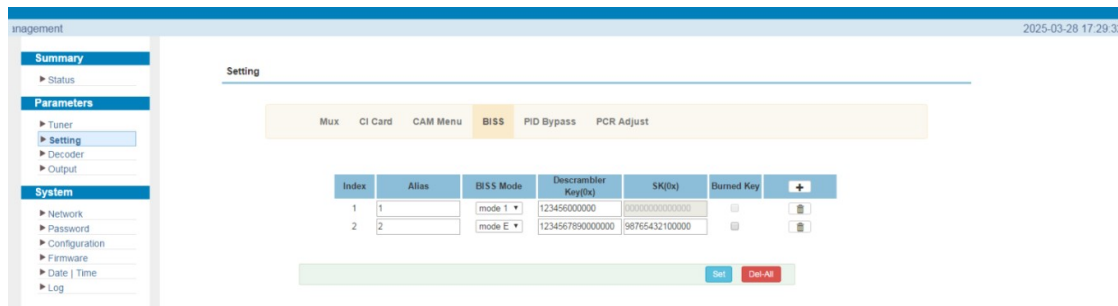

Figure-9

Items showing above are working as per the keys or codes set in the BISS scrambling side (the corresponding modulators).

Input corresponding items and data to active the BISS descrambling as principles be

Modulating Side (BISS SCR)	Receiving Side (BISS DESCR)	Digit (0x----)
Mode 1+SW Data	Mode 1+Descrambler Key	12
Mode E+ESW Data + Device	Mode E + Descrambler Key + Burned Key	16
Mode E+ESW Data + Input ID	Mode E + Descrambler Key + SK	14

*After adding the above BISS keys, users need to come back to the Mux Web page and click

the selected program name in BISS channel to get a pop-up window where the right BISS key will be selected and applied to descramble the corresponding program.

PID Bypass:

Users can bypass the wanted PID to the output as below:

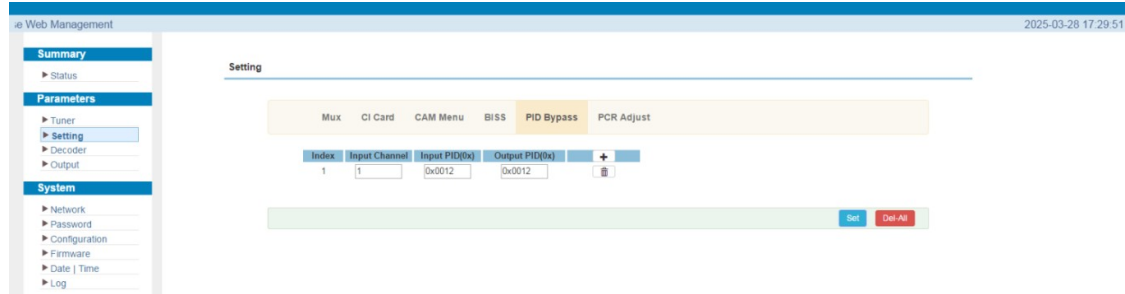

PCR Adjust:

Users can adjust PCR performance if necessary. For more information, please contact our technician for a guide.

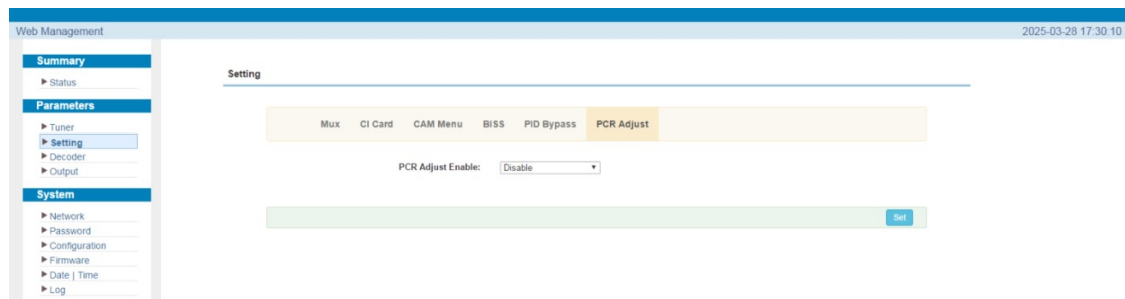

Parameters → Decoder:

H-IP-ASI-B-V3 supports decoding one TV program, with max 2 audios (hardware option). Users can configure the Video/Audio output parameters in this Web page. Audio 2 will work only when the ordered version supports 2 audio decoding. (Figure-10)

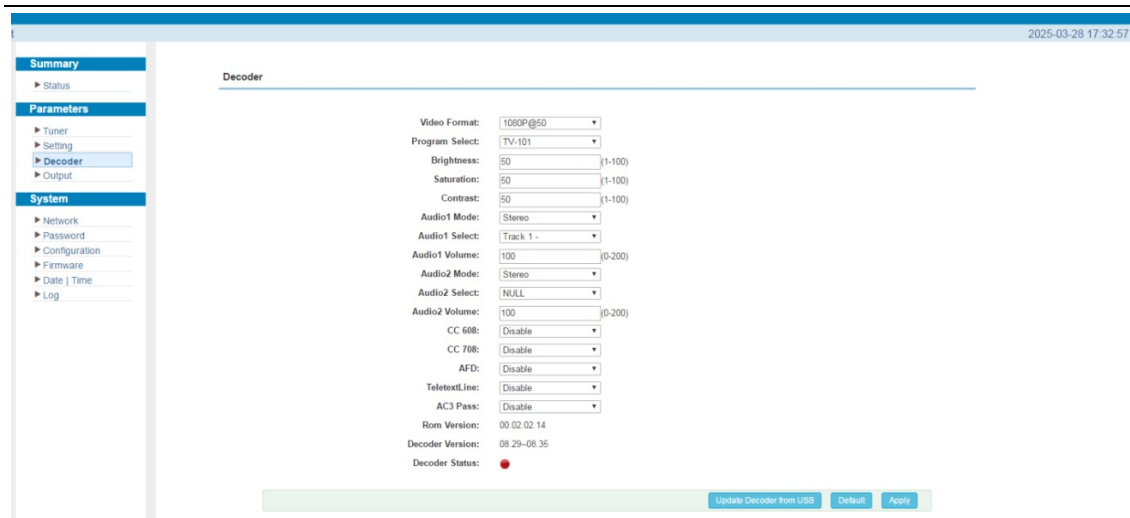

Figure-10

*Some professional parameters, such as AFD, please contact our technician for setting guide.

Parameters →Output:

This ASI converter supports TS output via IP (1 MPTS & 16 SPTS) and via ASI out. Click “Output” and it displays the interface where users can configure the MPTS & SPTS out parameters. (Figure-11)

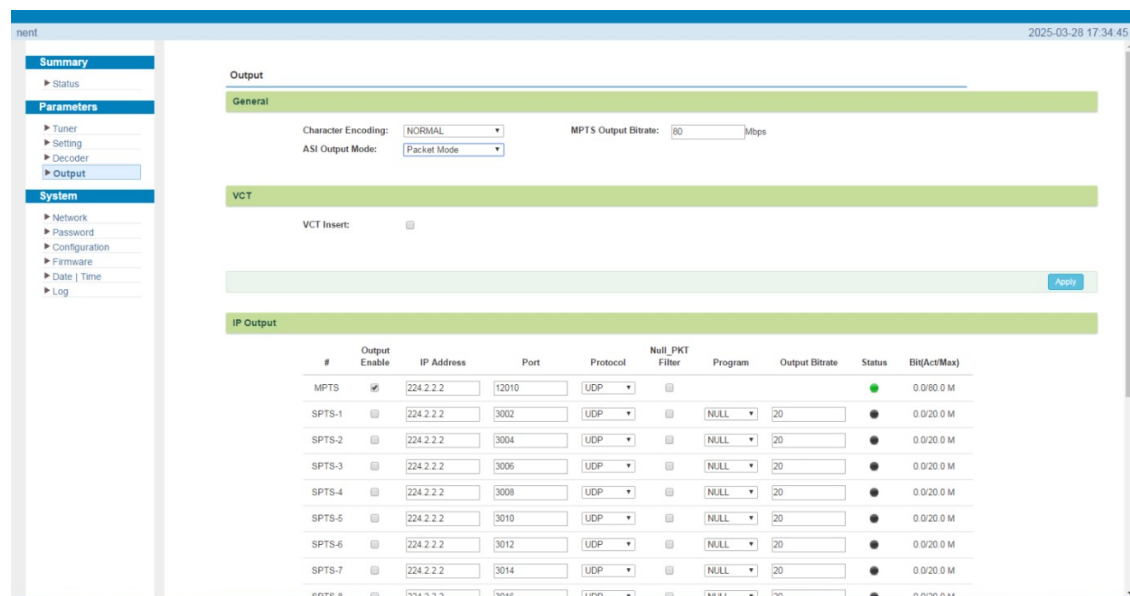

Figure-11

In this page, user can enable or disable the corresponding IP output, modify the output address and port, modify the output protocol, define which SPTS is for which program,



and set the MPTS output bitrate in this page.

Output

General

Character Encoding: MPTS Output Bitrate: Mbps

ASI Output Mode:

VCT

VCT Insert:

#	Output Enable	IP Address	Port	Protocol	Null_PKT Filter	Program	Output Bitrate	Status	Bit(Act/Max)
MPTS	<input checked="" type="checkbox"/>	<input type="text" value="224.2.2.2"/>	<input type="text" value="12010"/>	<input type="text" value="UDP"/>	<input type="checkbox"/>			●	0.0/80.0 M
SPTS-1	<input type="checkbox"/>	<input type="text" value="224.2.2.2"/>	<input type="text" value="3002"/>	<input type="text" value="UDP"/>	<input type="checkbox"/>	<input type="text" value="NULL"/>	<input type="text" value="20"/>	●	0.0/20.0 M
SPTS-2	<input type="checkbox"/>	<input type="text" value="224.2.2.2"/>	<input type="text" value="3004"/>	<input type="text" value="UDP"/>	<input type="checkbox"/>	<input type="text" value="TV-101"/>	<input type="text" value="20"/>	●	0.0/20.0 M
SPTS-3	<input type="checkbox"/>	<input type="text" value="224.2.2.2"/>	<input type="text" value="3006"/>	<input type="text" value="UDP"/>	<input type="checkbox"/>	<input type="text" value="NULL"/>	<input type="text" value="20"/>	●	0.0/20.0 M

***Character Encoding:** users can choose the option as per their language environments.

***ASI Output Mode:** Packet Mode and Byte Mode, usually it is Packet Mode by default.

Byte mode is used in some special case where only Byte mode can enable the TS locking at the receiver side. Please contact our technician for setting guide when you need to use it.

After finishing the configuration, click to confirm.

System → Network:

From the menu on left side of the webpage, clicking “Network”, it will display the screen as Figure-12 where to configure the network parameters for the device.

Figure-12

System → Password:



From the menu on left side of the webpage, clicking “Password”, it will display the screen as Figure-13 where to set the login account and password for the web NMS.

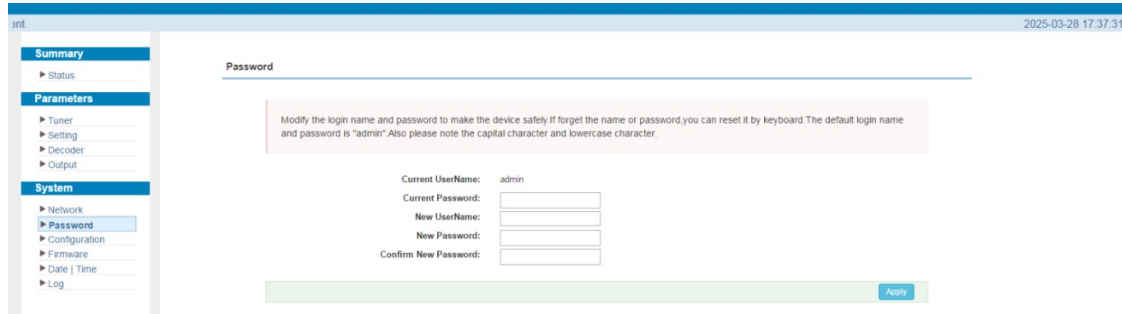

Figure-13

System → Configuration:

From the menu on left side of the webpage, clicking “Configuration”, it will display the screen as Figure-14 where to save, restore, make factory set, backup and load your configurations.

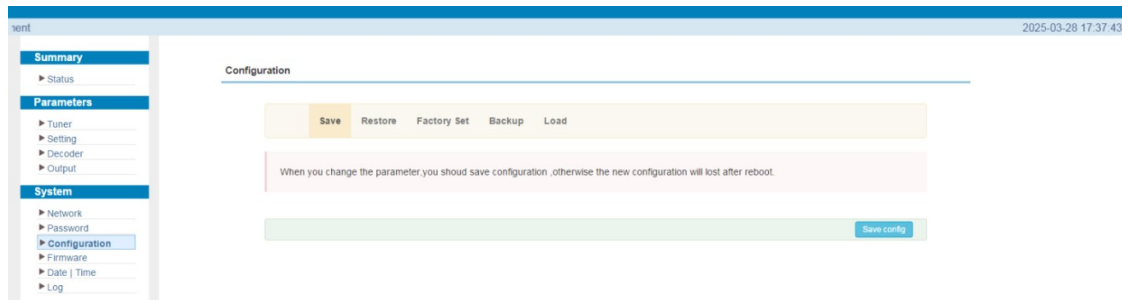

Figure-14

System → Firmware:

From the menu on left side of the webpage, clicking “Firmware”, it will display the screen as Figure-15 where to update firmware for the device.

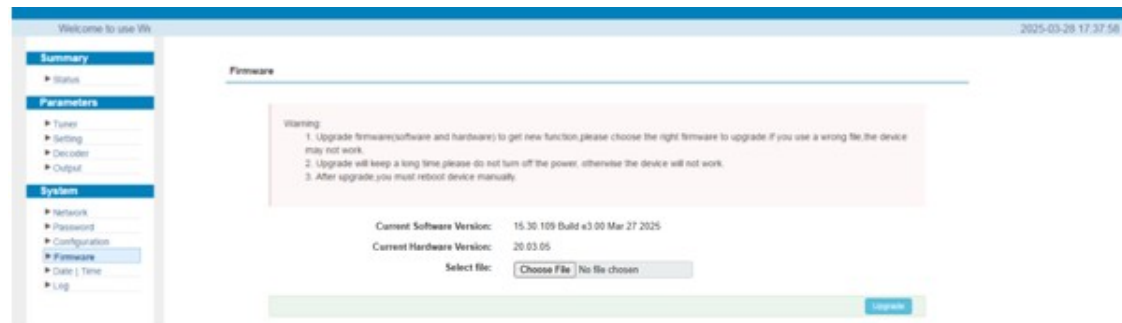

Figure-15

System → Date/Time:



Users can set timezone and configure NTP server to update Date and Time in the device.

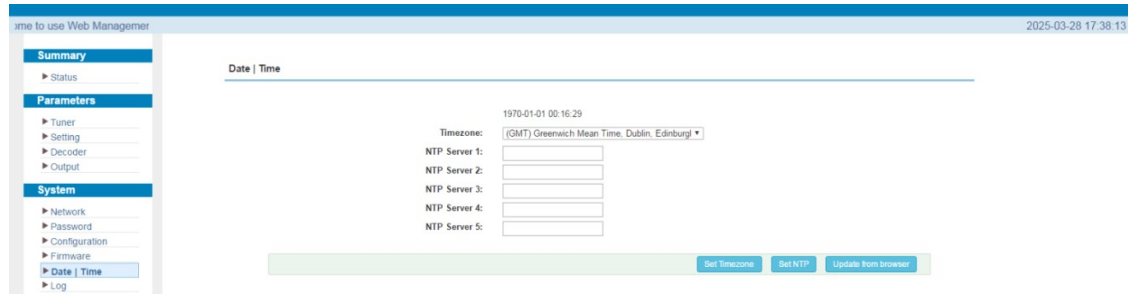

Figure-16

System → Log:

The Kernel and System log here are for the R&D debugging reference.

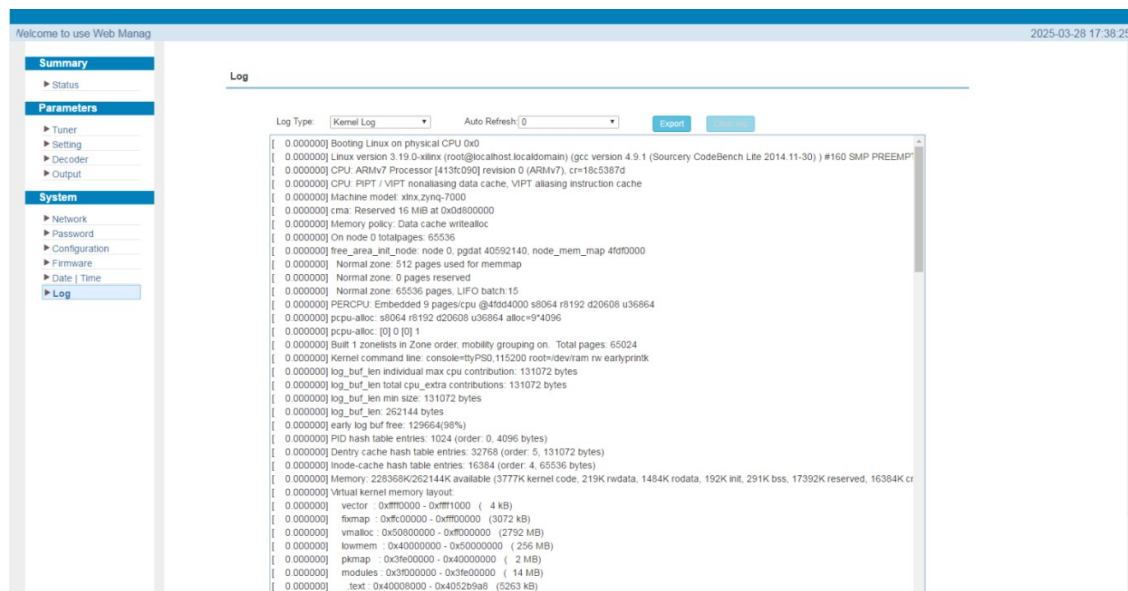

Figure-17

Chapter 5 Troubleshooting

THOR's ISO9001 quality assurance system has been approved by CQC organization. For guarantee the products' quality, reliability and stability. All THOR products have been passed the testing and inspection before ship out factory. The testing and inspection scheme already covers all the Optical, Electronic and Mechanical criteria which have been published by THOR. To prevent potential hazard, please strictly follow the operation conditions.

Prevention Measure



- Installing the device at the place in which environment temperature between 0 to 45 °C
- Making sure good ventilation for the heat-sink on the rear panel and other heat-sink bores if necessary
- Checking the input AC voltage within the power supply working range and the connection is correct before switching on device
- Checking the RF output level varies within tolerant range if it is necessary
- Checking all signal cables have been properly connected
- Frequently switching on/off device is prohibited; the interval between every switching on/off must greater than 10 seconds.

Conditions need to unplug power cord

- Power cord or socket damaged.
- Any liquid flowed into device.
- Any stuff causes circuit short
- Device in damp environment
- Device was suffered from physical damage
- Longtime idle.
- After switching on and restoring to factory setting, device still cannot work properly.
- Maintenance needed